



ENGINE

Model	ISM N844L-F
Emissions Certification	Tier 4 Final
Type	Diesel 4-stroke, naturally aspirated
Cylinders	4
Bore/Stroke	3.31 x 3.94 in (84 x 100 mm)
Displacement	135.2 in ³ (2.2 L)
Fuel injection	Indirect
Fuel	#2 Diesel
Fuel filter:	
Pre-filter	14 micron/in line
Main filter	10 micron/spin-on
Air intake	Naturally aspirated w/o EGR
Exhaust aftertreatment	Diesel Particulate Filter – DPF
Cooling	Liquid
Engine speeds	RPM
High idle – no load	2825 +/- 25
Rated – full load	2800
Low idle	1200 +/- 50
Horsepower @ 2800 RPM – SAE J1349:	
Gross	48.8 hp (36.4 kW)
Net	45.8 hp (34.1 kW)
Peak torque @ 1800 RPM	105.5 lb-ft (143 N·m)
Radiator:	
Core type	All aluminum
Core size area	2.77 ft ² (0.257 m ²)
Rows of tubes x columns	43 x 3
Cap pressure	16 +/- 2 psi (1.10 +/- 0.14 bar)
Fan:	
Diameter	17.7 in (450 mm)
Ratio	0.89:1
Water pump:	
Style	Centrifugal
Flow	19.0 gpm (71.9 L/min)
Engine lubrication pump	Pressure feed w/ Trichoid pump
Pump operating angle ratings:	
Side to side	35°
Bucket up	35°
Bucket Down	35°

LIFT GEOMETRY

Radial Lift

DRIVETRAIN

Drive pump controls	Direct mechanical
Pump to engine ratio	1:1
Displacement	2.14 in ³ (35 cm ³)
Flow @ rated engine RPM:	
@ 97% efficiency	25.1 gpm (95 L/min)
Charge pressure	360 psi (24.5 bar)
System relief pressure	5,000 psi (345 bar)

Drive pump controls	Electro-hydraulic
Pump to engine ratio	1:1
Displacement	2.14 in ³ (35 cm ³)
Flow @ rated engine RPM:	
@ 97% efficiency	25.1 gpm (95 L/min)
Charge pressure	362 psi (24.5 bar)
System relief pressure	5,220 psi (360 bar)

Drive motors:	
Displacement	19.8 in ³ (325 cm ³)
Motor RPM @ high idle and 97% efficiency	313
Max. torque @ 5,000 psi (345 bar):	1,315 lb-ft (1 783 N·m)

Travel speed	7.4 mph (11.9 kph)
Final drive	Single-reduction chain drive

Drive chain:	
Size	ASA #80
Tensile strength	21,000 lb (93.4 kN)

Axles:	
Torque	4,381 lb-ft (5 940 N·m)
Diameter	2.0 in (50.8 mm)
Length	13.2 in (346.0 mm)

Parking brake:	
Type	Spring-applied, hydraulic release multiple disc.
Engagement	Depress on/off brake button on handle or instrument panel, raise seat bar, get off seat or stop engine.

ELECTRICAL

Alternator	120 amp
Starter	2.95 hp (2.2 kW)

Battery	12-volt low-maintenance 925 cold-cranking amps @ 0° F (-18° C°)
---------	--

OPERATOR ENVIRONMENT

ROPS/FOPS Level 1 canopy w/ side screens; Keyed start ignition; Tilt ROPS/FOPS; Rear window w/ emergency escape; Suspension Seat, vinyl w/ 2 in (51 mm) retractable 3 point lap seat belt; Hand and foot throttle; Alarm package – back-up and horn; Headliner; Dome Light; Top window; Cup holder; 12V Power plug socket; Foot rest; Seat pocket; Padded seat bar w/ integral armrests; Loader control lockout system; Electric parking brake control; Operator's compartment floor cleanout; Proportional auxiliary hydraulic control – on joystick; Advanced Instrument Cluster w/ digital hour meter,

tachometer, fuel level LCD bar graph w/ alarm, diagnostic features and security lockout.

Warning lights with alarms:

Engine coolant temperature; Engine oil pressure; Engine malfunction; Hydraulic charge pressure; Hydraulic filter restriction; Hydraulic oil temperature; Critical system stop, Engine system, Hydraulic system, Electrical and diagnostic system.

Warning alarms:

Battery voltage – plus display; Oil service.

Indicator light:

Engine preheat; Parking brake;
Seat bar reminder.

OPERATING WEIGHT

Unit equipped w/ open cab; 165 lb operator;
60 in Dirt & Foundry bucket; full of fuel;
10 x 16.5 tires: 5,070 lb (2 300 kg)

Shipping weight 4,770 lb (2 160 kg)

Add-on weights:

Side cab glass	47 lb (21.3 kg)
Polycarbonate cab door	74 lb (33.6 kg)
Glass cab door w/ wiper	134 lb (60.8 kg)
Suspension seat	22 lb (10.0 kg)
Additional counterweight	168 lb (76.2 kg)

HYDRAULICS

Implement pump type	Gear
Displacement	1.45 in ³ (23.8 cm ³)

Standard flow @ rated engine RPM:
@ 100% efficiency 17.5 gpm (66.2 L/min)

Loader control valve:

Type	3 spool/open center/series - series
Relief pressure	3,050 psi (210 bar)

Port relief pressures:

Loader raise	3,263 psi (225 bar)
Bucket curl	3,770 psi (260 bar)
Bucket dump	1,160 psi (80 bar)

Hydraulic lines:

Tubing	37° JIC Flare
Loop hoses	SAE 100 R19

Hydraulic oil cooler:

Number of fins	10 per inch (3.94 per cm)
Number of tube rows x columns	9 x 1
Area	130.7 in ² (843.2 cm ²)

Hydraulic filter	Beta (4) = 75/spin-on
------------------	-----------------------

Lift cylinders:

Bore diameter	2.25 in (57.2 mm)
Rod diameter	1.38 in (34.9 mm)
Stroke	25.40 in (645.0 mm)
Closed length	38.94 in (989.0 mm)

Bucket cylinders:

Bore diameter	2.25 in (57.2 mm)
Rod diameter	1.25 in (31.7 mm)
Stroke	14.57 in (370.1 mm)
Closed length	23.38 in (594.0 mm)

SERVICE CAPACITIES

Fuel tank	16.0 gal (60.5 L)
Engine oil w/ filter	7.5 qt (7.1 L)
Hydraulic system:	
Reservoir	4.0 gal (15.1 L)
Total	7.71 gal (29.2 L)
Chain tanks – per side	1.65 gal (6.5 L)

PERFORMANCE SPECS

Rated operating capacity – ROC*:	
50% of tipping load	1,300 lb (590 kg)
w/ additional counterweight	1,400 lb (635 kg)
Tipping load*	2,600 lb (1 179 kg)

Breakout forces @ 3,150 psi (217 bar)*:	
Bucket cylinders	4,180 lb (18.6 kN)
Lift cylinders – tip limit	2,850 lb (12.7 kN)

Cycle times:	
Raise	3.2 sec
Lower	2.0 sec
Dump	1.8 sec
Roll back	1.3 sec

NOTE: *Measured using 60 in (1.52 m) foundry/ excavating bucket.

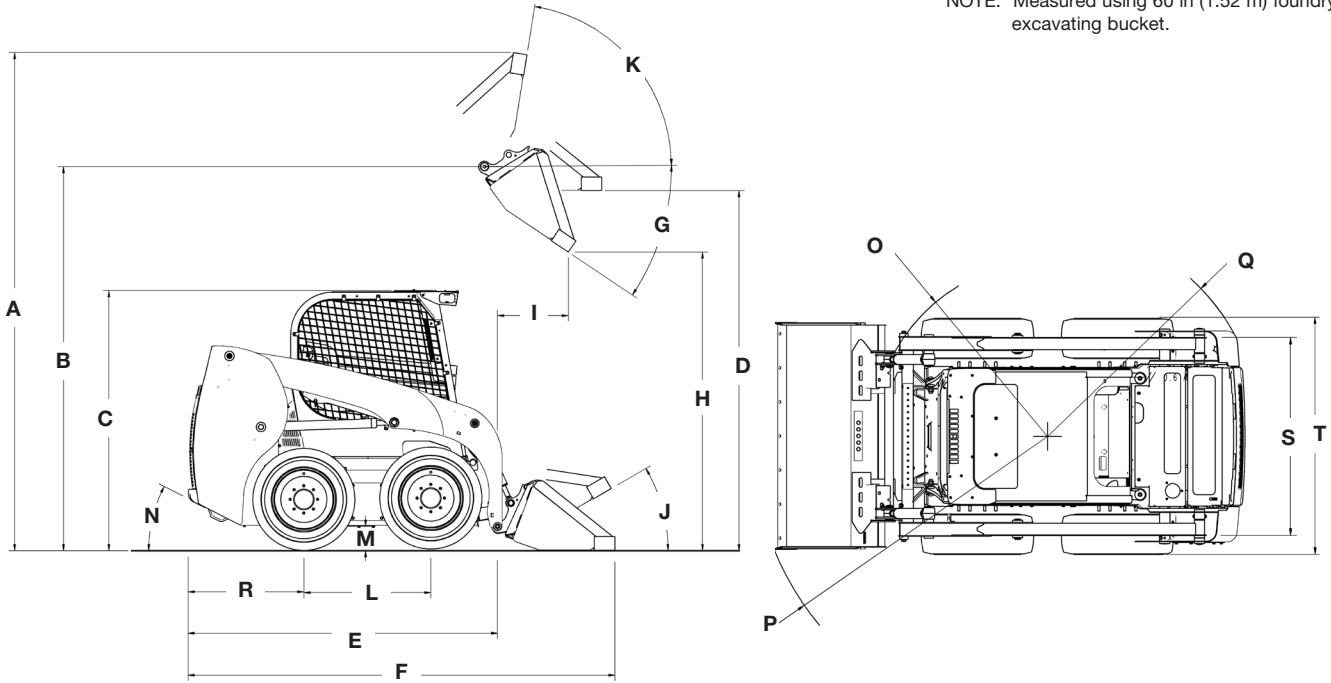

Line drawings are for illustrative purpose only and may not be exact representation of unit.

DIMENSIONS

A. Overall operating height:	
with foundry/excavating bucket	141.4 in (3.59 m)
with low profile bucket	146.9 in (3.73 m)
with low profile extended bucket	152.0 in (3.86 m)
Height to:	
B. Bucket hinge pin	112.0 in (2.85 m)
C. Top of ROPS	75.5 in (1.92 m)
D. Bottom of level bucket, fully raised	105.6 in (2.68 m)
Overall length:	
E. without attachment with coupler	95.9 in (2.44 m)
F. with foundry/excavating bucket on ground	119.2 in (3.03 m)
with low profile bucket	125.0 in (3.18 m)
with low profile extended bucket	129.8 in (3.30 m)
G. Maximum dump angle	40.2°
H. Dump height:	
with foundry/excavating bucket	88.4 in (2.25 m) @ 40.2°
with low profile bucket	84.8 in (2.15 m) @ 40.2°
I. Dump reach at maximum height with low profile bucket	22.7 in (0.58 m) @ 40.2°
Maximum attachment rollback:	
J. Bucket on ground	26.1°
K. Bucket at full height	95.2°
L. Wheelbase	37.0 in (0.94 m)
M. Ground clearance – bottom of belly pan	7.0 in (0.18 m)
N. Angle of departure	22.0°
Clearance circle:	
O. without bucket	48.7 in (1.24 m)
P. with 60 in (1.52 m) foundry/excavating bucket in carry position	73.3 in (1.86 m)
with 60 in (1.52 m) low profile bucket on ground	78.5 in (1.99 m)
with 60 in (1.52 m) extended low profile on ground	83.1 in (2.11 m)
Q. Clearance circle rear	56.4 in (1.43 m)
R. Rear axle to bumper	33.8 in (0.86 m)
S. Tread over gauge with spec tires	49.2 in (1.25 m)
T. Over the tire width spec tires	59.0 in (1.50 m)

TIRE SELECTION

Type	Size	Tread Gauge	Over Tires Width	Each Tire Weight*
Heavy-Duty	10 L x 16.5	49.2 in (1.25 m)	59.0 in (1.50 m)	87 lb (39.5 kg)
Premium	10 L x 16.5	49.2 in (1.25 m)	59.0 in (1.50 m)	96 lb (44.0 kg)
Premium-Lined	10 L x 16.5	49.2 in (1.25 m)	59.0 in (1.50 m)	63 lb (28.5 kg)
Non-Pneumatic – Solid	10 L x 16.5	51.0 in (1.29 m)	64.0 in (1.55 m)	229 lb (104.0 kg)
Premium	27 L x 10.5-15	—	64.0 in (1.63 m)	69 lb (31.0 kg)

NOTE: *Tire weight does not include the wheel weight.

OPTIONAL BUCKETS

Type	Width	Weight	Heaped Capacity
Dirt & Foundry	60 in (1.52 m)	300 lb (138 kg)	11.3 ft ³ (0.32 m ³)
	66 in (1.68 m)	385 lb (175 kg)	14.8 ft ³ (0.42 m ³)
	72 in (1.83 m)	420 lb (190 kg)	16.2 ft ³ (0.46 m ³)
Low Profile	60 in (1.52 m)	375 lb (170 kg)	12.0 ft ³ (0.34 m ³)
	66 in (1.68 m)	440 lb (200 kg)	13.4 ft ³ (0.38 m ³)
	72 in (1.83 m)	480 lb (218 kg)	14.8 ft ³ (0.42 m ³)
Low Profile Extended	60 in (1.52 m)	400 lb (182 kg)	14.1 ft ³ (0.40 m ³)
	66 in (1.68 m)	470 lb (214 kg)	15.9 ft ³ (0.45 m ³)
	72 in (1.83 m)	510 lb (232 kg)	17.7 ft ³ (0.50 m ³)
Light Material	60 in (1.52 m)	375 lb (170 kg)	19.4 ft ³ (0.55 m ³)
	72 in (1.83 m)	475 lb (216 kg)	23.3 ft ³ (0.66 m ³)
Manure & Slurry	60 in (1.52 m)	370 lb (168 kg)	15.9 ft ³ (0.45 m ³)
	72 in (1.83 m)	480 lb (218 kg)	19.1 ft ³ (0.54 m ³)
Heavy-Duty	66 in (1.68 m)	450 lb (205 kg)	13.1 ft ³ (0.37 m ³)
	72 in (1.83 m)	510 lb (230 kg)	14.1 ft ³ (0.40 m ³)
Heavy-Duty with spillguard	66 in (1.68 m)	520 lb (235 kg)	16.6 ft ³ (0.47 m ³)
	72 in (1.83 m)	585 lb (265 kg)	18.4 ft ³ (0.52 m ³)

STANDARD EQUIPMENT

OPERATOR ENVIRONMENT

See page 1

ENGINE

ISM N844L-F diesel
135.2 CID (2.2 L) Naturally Aspirated
Tier 4 Final Certified
Spark Arresting Diesel Particulate Filter (DPF) muffler
Charged Air Cooler (CAC)
Indirect fuel injection
Horsepower:
Gross: 48.8 hp (36.4 kW)
Net: 45.8 hp (34.1 kW)
Peak torque: 105.5 lb-ft (143 N·m)
120 amp alternator
Dual element air cleaner
Organic Acid Technology (OAT)
Anti-freeze solution to -34° F
Fuel tank - 16 gal (U.S.)
Over and under radiator and oil cooler
Single plane, top and bottom oil cooler/
radiator configuration
Glow plugs

Integral engine oil cooler
Fuel filter with water trap
925 CCA 12V battery
Master electrical disconnect

DRIVETRAIN

1-speed hydrostatic four wheel drive
ASA #80 drive chain
SAHR disc parking brake

HYDRAULICS

Auxiliary hydraulics:
@ 3,050 psi (210 bar) – 17.5 gpm
(66.2 L/min)
6 micron oil filtration system
3-spool loader control valve
Auxiliary hydraulic disconnects, ISO
flat-face – connect-under-pressure
with case drain
Hydraulic circuit pedal lock
Auxiliary function lockout override
Loader lift lockout override
Heavy-duty hydraulic oil cooler
Loader arm float position
Loader function lockout system

LOADER

Manual attachment coupler
Radial lift geometry
Loader lift arm support strut
SAE operating load: 1,300 lbs
Tipping load: 2,600 lbs

TIRES

10 X 16.5 Heavy duty

OTHER STANDARD FEATURES

Halogen lights - 2 front, 2 side, 2 rear flood
Heavy duty front lights
Pre-wired for rotating beacon
Lockable service access hood
Single-point daily service
Rear tail lights
Remote oil drain
Remote oil and fuel filters
Block heater
Debris ingress sealing
Mounting points for add-on counterweights

OPTIONAL EQUIPMENT

OPERATOR ENVIRONMENT

Enclosed cab:
Fully sealed and pressurized – FSP
Glass door with wiper and washer
Sliding side windows – removable
Ventilation system with integrated heater
AM/FM radio with 2 speakers
Keyless start ignition
Control lockout system
Electro-hydraulic controls:
For drive/steering, loader functions
Switchable between H and ISO patterns
Adjustable sensitivity of controls
Mechanical hand controls
Hand and foot controls:
Hand controls the loader drive function
and foot controls the bucket and boom
Non suspension seat
Deluxe cloth, air suspension seat, with heater
and lumbar support
Open cab interior trim package
Demolition cab door with polycarbonate
FOPS level 2

HYDRAULICS

Second auxiliary hydraulic
Hydraulic one-way self-leveling
Ride control

LOADER

Auxiliary front electric control
Hydraulic attachment coupler

OTHER

Language decals
Factory-installed tires – see page 3
Buckets – see page 3
Bolt-on bucket cutting edges
Bolt-on heavy-duty bucket spill guard
Special paint
Offsite service arrangement
Telematics

FACTORY SUPPLIED ATTACHMENTS

Interior mirror
Add-on counterweights
Road lights
Rotating beacon
Four-corner LED strobe
Bolt-on heavy-duty bucket teeth
48 in (1.22 m) pallet forks

SERVICE PARTS

3 inch (76.2 mm) retractable seat belt

CaseCE.com

©2016 CNH Industrial America LLC. All rights reserved. CASE is a trademark registered in the United States and many other countries, owned by or licensed to CNH Industrial N.V., its subsidiaries or affiliates. CNH Industrial Capital is a trademark in the United States and many other countries, owned by or licensed to CNH Industrial N.V., its subsidiaries or affiliates. Printed in U.S.A. Contains 10% post-consumer fiber.

IMPORTANT: CASE Construction Equipment Inc. reserves the right to change these specifications without notice and without incurring any obligation relating to such change. Availability of some models and equipment builds vary according to the country in which the equipment is used. The illustrations and text may include optional equipment and accessories and may not include all standard equipment. Your CASE dealer/distributor will be able to give you details of the products and their specifications available in your area.



CASE Construction Equipment is biodiesel-friendly. NOTE: All engines meet current EPA emissions regulations. All specifications are stated in accordance with SAE Standards or Recommended Practices, where applicable.



Always read the Operator's Manual before operating any equipment. Inspect equipment before using it, and be sure it is operating properly. Follow the product safety signs and use any safety features provided.

Form No. CCE201608SR130T4
Replaces Form No. CCE201603SR130T4