



## ENGINE

Model	ISM N844LT-F
Emissions Certification	Tier 4 Final
Type	Diesel 4-stroke, turbocharged
Cylinders	4
Bore/Stroke	3.31 x 3.94 in (84 x 100 mm)
Displacement	135.2 in <sup>3</sup> (2.2 L)
Fuel injection	Indirect
Fuel	#2 Diesel
Fuel filter:	
Pre-filter	14 micron/in line
Main filter	10 micron/spin-on
Air intake	Turbocharged w/ waste gate and external cooled EGR
Exhaust aftertreatment	Diesel Particulate Filter – DPF
Cooling	Liquid
Engine speeds	RPM
High idle – no load	2825 +/- 25
Rated – full load	2800
Low idle	1200 +/- 50
Horsepower @ 2800 RPM – SAE J1349:	
Gross	60 hp (44.7 kW)
Net	57 hp (42.4 kW)
Peak torque @ 1800 RPM	139 lb-ft (188 N-m)
Radiator:	
Core type	All aluminum
Core size area	2.77 ft <sup>2</sup> (0.257 m <sup>2</sup> )
Rows of tubes x columns	43 x 3
Cap pressure	16 +/- 2 psi (1.10 +/- 0.14 bar)
Fan:	
Diameter	17.7 in (450 mm)
Ratio	0.89:1
Water pump:	
Style	Centrifugal
Flow	14.7 gpm (55.5 L/min)
Engine lubrication pump	Pressure feed w/ Trichoid pump
Pump operating angle ratings:	
Side to side	35°
Bucket up	35°
Bucket Down	35°

## LIFT GEOMETRY

Radial Lift

## DRIVETRAIN

Drive pump controls	Direct mechanical
Pump to engine ratio	1:1
Displacement	2.14 in <sup>3</sup> (35 cm <sup>3</sup> )
Flow @ rated engine RPM:	
@ 97% efficiency	25.1 gpm (95 L/min)
Charge pressure	360 psi (24.5 bar)
System relief pressure	5,000 psi (345 bar)
Drive pump controls	Electro-hydraulic
Pump to engine ratio	1:1
Displacement	2.14 in <sup>3</sup> (35 cm <sup>3</sup> )
Flow @ rated engine RPM:	
@ 97% efficiency	25.1 gpm (95 L/min)
Charge pressure	362 psi (24.5 bar)
System relief pressure	5,220 psi (360 bar)
Drive motors:	
Displacement	19.8 in <sup>3</sup> (325 cm <sup>3</sup> )
Motor RPM @ high idle and 97% efficiency	313
Max. torque @ 5,000 psi (345 bar):	1,315 lb-ft (1 783 N-m)
Travel speed	7.4 mph (11.9 kph)
Final drive	Single-reduction chain drive
Drive chain:	
Size	ASA #80
Tensile strength	21,000 lb (93.4 kN)
Axles:	
Torque	4,381 lb-ft (5 940 N-m)
Diameter	2.0 in (50.8 mm)
Length	13.2 in (346.0 mm)
Parking brake:	
Type	Spring-applied, hydraulic release multiple disc.
Engagement	Depress on/off brake button on handle or instrument panel, raise seat bar, get off seat or stop engine.

## ELECTRICAL

Alternator	120 amp
Starter	2.95 hp (2.2 kW)
Battery	12-volt low-maintenance 925 cold-cranking amps @ 0° F (-18° C°)

## OPERATOR ENVIRONMENT

ROPS/FOPS Level 1 canopy w/ side screens; Keyed start ignition; Tilt ROPS/FOPS; Rear window w/ emergency escape; Suspension Seat, vinyl w/ 2 in (51 mm) retractable 3 point lap seat belt; Hand and foot throttle; Alarm package – back-up and horn; Headliner; Dome Light; Top window; Cup holder; 12V Power plug socket; Foot rest; Seat pocket; Padded seat bar w/ integral armrests; Loader control lockout system; Electric parking brake control; Operator's compartment floor cleanout; Proportional auxiliary hydraulic control – on joystick; Advanced Instrument Cluster w/ digital hour meter,

tachometer, fuel level LCD bar graph w/ alarm, diagnostic features and security lockout.

Warning lights with alarms:

Engine coolant temperature; Engine oil pressure; Engine malfunction; Hydraulic charge pressure; Hydraulic filter restriction; Hydraulic oil temperature: Critical system stop, Engine system, Hydraulic system, Electrical and diagnostic system.

Warning alarms:

Battery voltage – plus display; Oil service.

Indicator light:

Engine preheat; Parking brake; Seat bar reminder.

## OPERATING WEIGHT

Unit equipped w/ open cab; 165 lb operator; 60 in Dirt & Foundry bucket; full of fuel; 10 x 16.5 tires:	5,510 lb (2 505 kg)
Shipping weight	5,210 lb (2 370 kg)
Add-on weights:	
Side cab glass	47 lb (21.3 kg)
Polycarbonate cab door	74 lb (33.6 kg)
Glass cab door w/ wiper	134 lb (60.8 kg)
Suspension seat	22 lb (10.0 kg)
Additional counterweight	168 lb (76.2 kg)

## HYDRAULICS

Implement pump type	Gear
Displacement	1.52 in <sup>3</sup> (24.9 cm <sup>3</sup> )
Standard flow @ rated engine RPM: @ 100% efficiency	18.4 gpm (69.7 L/min)
Loader control valve:	
Type	3 spool/open center/series - series
Relief pressure	3,050 psi (210 bar)
Port relief pressures:	
Loader raise	3,263 psi (225 bar)
Bucket curl	3,770 psi (260 bar)
Bucket dump	1,160 psi (80 bar)
Hydraulic lines:	
Tubing	37° JIC Flare
Loop hoses	SAE 100 R19
Hydraulic oil cooler:	
Number of fins	10 per inch (3.94 per cm)
Number of tube rows x columns	9 x 1
Area	130.7 in <sup>2</sup> (843.2 cm <sup>2</sup> )
Hydraulic filter	Beta (4) = 75/spin-on
Lift cylinders:	
Bore diameter	2.25 in (57.2 mm)
Rod diameter	1.38 in (34.9 mm)
Stroke	25.40 in (645.0 mm)
Closed length	38.94 in (989.0 mm)
Bucket cylinders:	
Bore diameter	2.50 in (63.5 mm)
Rod diameter	1.38 in (35.0 mm)
Stroke	14.57 in (370.1 mm)
Closed length	23.38 in (594.0 mm)

## SERVICE CAPACITIES

Fuel tank	16.0 gal (60.5 L)
Engine oil w/ filter	7.5 qt (7.1 L)
Hydraulic system:	
Reservoir	4.0 gal (15.1 L)
Total	7.71 gal (29.2 L)
Chain tanks – per side	1.65 gal (6.5 L)

## PERFORMANCE SPECS

Rated operating capacity – ROC*:	
50% of tipping load	1,600 lb (726 kg)
w/ additional counterweight	1,700 lb (771 kg)
Tipping load*	3,200 lb (1 455 kg)

Breakout forces @ 3,150 psi (217 bar)*:	
Bucket cylinders	5,270 lb (23.4 kN)
Lift cylinders – tip limit	3,310 lb (14.7 kN)

Cycle times:	
Raise	3.0 sec
Lower	1.9 sec
Dump	2.1 sec
Roll back	1.5 sec

NOTE: \*Measured using 60 in (1.52 m) foundry/ excavating bucket.

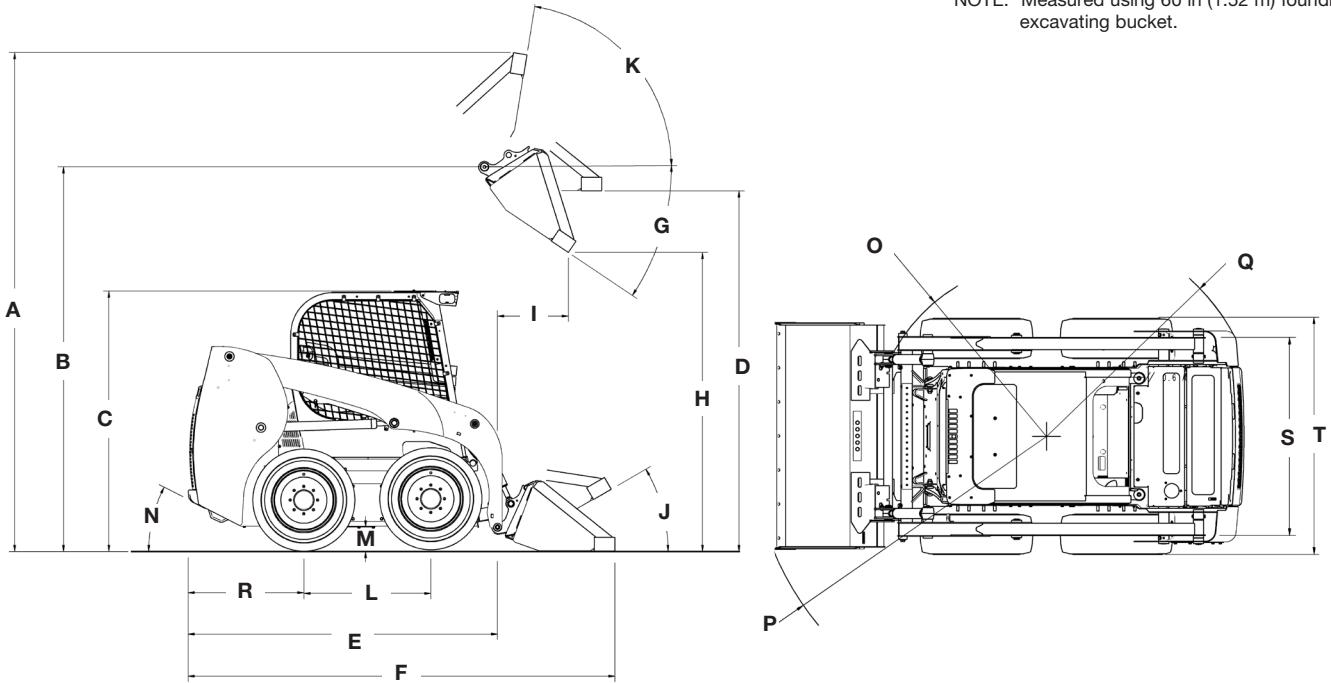

Line drawings are for illustrative purpose only and may not be exact representation of unit.

## DIMENSIONS

<b>A.</b> Overall operating height:	
with foundry/excavating bucket	141.4 in (3.59 m)
with low profile bucket	146.9 in (3.73 m)
with low profile extended bucket	152.0 in (3.86 m)
Height to:	
<b>B.</b> Bucket hinge pin	112.0 in (2.85 m)
<b>C.</b> Top of ROPS	75.5 in (1.92 m)
<b>D.</b> Bottom of level bucket, fully raised	105.6 in (2.68 m)
Overall length:	
<b>E.</b> without attachment with coupler	95.9 in (2.44 m)
<b>F.</b> with foundry/excavating bucket on ground	119.2 in (3.03 m)
with low profile bucket	125.0 in (3.18 m)
with low profile extended bucket	129.8 in (3.30 m)
<b>G.</b> Maximum dump angle	40.2°
<b>H.</b> Dump height:	
with foundry/excavating bucket	88.4 in (2.25 m) @ 40.2°
with low profile bucket	84.8 in (2.15 m) @ 40.2°
<b>I.</b> Dump reach at maximum height with low profile bucket	22.7 in (0.58 m) @ 40.2°
Maximum attachment rollback:	
<b>J.</b> Bucket on ground	26.1°
<b>K.</b> Bucket at full height	95.2°
<b>L.</b> Wheelbase	37.0 in (0.94 m)
<b>M.</b> Ground clearance – bottom of belly pan	7.0 in (0.18 m)
<b>N.</b> Angle of departure	22.0°
Clearance circle:	
<b>O.</b> without bucket	48.7 in (1.24 m)
<b>P.</b> with 60 in (1.52 m) foundry/excavating bucket in carry position	73.3 in (1.86 m)
with 60 in (1.52 m) low profile bucket on ground	78.5 in (1.99 m)
with 60 in (1.52 m) extended low profile on ground	83.1 in (2.11 m)
<b>Q.</b> Clearance circle rear	56.4 in (1.43 m)
<b>R.</b> Rear axle to bumper	33.8 in (0.86 m)
<b>S.</b> Tread over gauge with spec lines	49.2 in (1.25 m)
<b>T.</b> Over the tire width spec tires	59.0 in (1.50 m)

## TIRE SELECTION

Type	Size	Tread Gauge	Over Tires Width	Each Tire Weight*
Heavy-Duty	10 L x 16.5	49.2 in (1.25 m)	59.0 in (1.50 m)	87 lb (39.5 kg)
Premium	10 L x 16.5	49.2 in (1.25 m)	59.0 in (1.50 m)	96 lb (44.0 kg)
Premium-Lined	10 L x 16.5	49.2 in (1.25 m)	59.0 in (1.50 m)	63 lb (28.5 kg)
Non-Pneumatic – Solid	10 L x 16.5	51.0 in (1.29 m)	64.0 in (1.55 m)	229 lb (104.0 kg)
Premium	27 L x 10.5-15	—	64.0 in (1.63 m)	69 lb (31.0 kg)

NOTE: \*Tire weight does not include the wheel weight.

## OPTIONAL BUCKETS

Type	Width	Weight	Heaped Capacity
Dirt & Foundry	60 in (1.52 m)	300 lb (138 kg)	11.3 ft <sup>3</sup> (0.32 m <sup>3</sup> )
	66 in (1.68 m)	385 lb (175 kg)	14.8 ft <sup>3</sup> (0.42 m <sup>3</sup> )
	72 in (1.83 m)	420 lb (190 kg)	16.2 ft <sup>3</sup> (0.46 m <sup>3</sup> )
Low Profile	60 in (1.52 m)	375 lb (170 kg)	12.0 ft <sup>3</sup> (0.34 m <sup>3</sup> )
	66 in (1.68 m)	440 lb (200 kg)	13.4 ft <sup>3</sup> (0.38 m <sup>3</sup> )
	72 in (1.83 m)	480 lb (218 kg)	14.8 ft <sup>3</sup> (0.42 m <sup>3</sup> )
Low Profile Extended	60 in (1.52 m)	400 lb (182 kg)	14.1 ft <sup>3</sup> (0.40 m <sup>3</sup> )
	66 in (1.68 m)	470 lb (214 kg)	15.9 ft <sup>3</sup> (0.45 m <sup>3</sup> )
	72 in (1.83 m)	510 lb (232 kg)	17.7 ft <sup>3</sup> (0.50 m <sup>3</sup> )
Light Material	60 in (1.52 m)	375 lb (170 kg)	19.4 ft <sup>3</sup> (0.55 m <sup>3</sup> )
	72 in (1.83 m)	475 lb (216 kg)	23.3 ft <sup>3</sup> (0.66 m <sup>3</sup> )
Manure & Slurry	60 in (1.52 m)	370 lb (168 kg)	15.9 ft <sup>3</sup> (0.45 m <sup>3</sup> )
	72 in (1.83 m)	480 lb (218 kg)	19.1 ft <sup>3</sup> (0.54 m <sup>3</sup> )
Heavy-Duty	66 in (1.68 m)	450 lb (205 kg)	13.1 ft <sup>3</sup> (0.37 m <sup>3</sup> )
	72 in (1.83 m)	510 lb (230 kg)	14.1 ft <sup>3</sup> (0.40 m <sup>3</sup> )
Heavy-Duty with spillguard	66 in (1.68 m)	520 lb (235 kg)	16.6 ft <sup>3</sup> (0.47 m <sup>3</sup> )
	72 in (1.83 m)	585 lb (265 kg)	18.4 ft <sup>3</sup> (0.52 m <sup>3</sup> )

## STANDARD EQUIPMENT

### OPERATOR ENVIRONMENT

See page 1

### ENGINE

ISM N844L-F diesel  
135.2 CID (2.2 L) Turbo  
Tier 4 Final Certified  
Spark Arresting Diesel Particulate Filter (DPF) muffler  
Charged Air Cooler (CAC)  
Indirect fuel injection  
Horsepower:  
Gross: 60 hp (44.7 kW)  
Net: 57 hp (42.4 kW)  
Peak torque: 139 lb-ft (188 N·m)  
120 amp alternator  
Dual element air cleaner  
Organic Acid Technology (OAT)  
Anti-freeze solution to -34° F  
Fuel tank - 16 gal (U.S.)  
Over and under radiator and oil cooler  
Single plane, top and bottom oil cooler/  
radiator configuration  
Glow plugs

Integral engine oil cooler  
Fuel filter with water trap  
925 CCA 12V battery  
Master electrical disconnect

### DRIVETRAIN

1-speed hydrostatic four wheel drive  
ASA #80 drive chain  
SAHR disc parking brake

### HYDRAULICS

Auxiliary hydraulics:  
@ 3,050 psi (210 bar) – 18.4 gpm  
(69.7 L/min)  
6 micron oil filtration system  
3-spool loader control valve  
Auxiliary hydraulic disconnects, ISO  
flat-face – connect-under-pressure  
with case drain  
Hydraulic circuit pedal lock  
Auxiliary function lockout override  
Loader lift lockout override  
Heavy-duty hydraulic oil cooler  
Loader arm float position  
Loader function lockout system

### LOADER

Manual attachment coupler  
Radial lift geometry  
Loader lift arm support strut  
SAE operating load: 1,600 lbs  
Tipping load: 3,200 lbs

### TIRES

10 X 16.5 Heavy duty

### OTHER STANDARD FEATURES

Halogen lights - 2 front, 2 side, 2 rear flood  
Heavy duty front lights  
Pre-wired for rotating beacon  
Lockable service access hood  
Single-point daily service  
Rear tail lights  
Remote oil drain  
Remote oil and fuel filters  
Block heater  
Debris ingress sealing  
Mounting points for add-on counterweights

## OPTIONAL EQUIPMENT

### OPERATOR ENVIRONMENT

Enclosed cab:  
Fully sealed and pressurized – FSP  
Glass door with wiper and washer  
Sliding side windows – removable  
Ventilation system with integrated heater  
AM/FM radio with 2 speakers  
Keyless start ignition  
Control lockout system  
Electro-hydraulic controls:  
For drive/steering, loader functions  
Switchable between H and ISO patterns  
Adjustable sensitivity of controls  
Mechanical hand controls  
Hand and foot controls:  
Hand controls the loader drive function  
and foot controls the bucket and boom  
Non suspension seat  
Deluxe cloth, air suspension seat, with heater  
and lumbar support  
Open cab interior trim package  
Demolition cab door with polycarbonate  
FOPS level 2

### HYDRAULICS

Second auxiliary hydraulics  
Hydraulic one-way self-leveling  
Ride control

### LOADER

Auxiliary front electric control  
Hydraulic attachment coupler

### OTHER

Language decals  
Factory-installed tires – see page 3  
Buckets – see page 3  
Bolt-on bucket cutting edges  
Bolt-on heavy-duty bucket spill guard  
Special paint  
Offsite service arrangement  
Telematics

### FACTORY SUPPLIED ATTACHMENTS

Interior mirror  
Add-on counterweights  
Road lights  
Rotating beacon  
Four-corner LED strobe  
Bolt-on heavy-duty bucket teeth  
48 in (1.22 m) pallet forks

### SERVICE PARTS

3 inch (76.2 mm) retractable seat belt

## CaseCE.com

©2016 CNH Industrial America LLC. All rights reserved. CASE is a trademark registered in the United States and many other countries, owned by or licensed to CNH Industrial N.V., its subsidiaries or affiliates. CNH Industrial Capital is a trademark in the United States and many other countries, owned by or licensed to CNH Industrial N.V., its subsidiaries or affiliates. Printed in U.S.A. Contains 10% post-consumer fiber.

IMPORTANT: CASE Construction Equipment Inc. reserves the right to change these specifications without notice and without incurring any obligation relating to such change. Availability of some models and equipment builds vary according to the country in which the equipment is used. The illustrations and text may include optional equipment and accessories and may not include all standard equipment. Your CASE dealer/distributor will be able to give you details of the products and their specifications available in your area.



CASE Construction Equipment is biodiesel-friendly. NOTE: All engines meet current EPA emissions regulations. All specifications are stated in accordance with SAE Standards or Recommended Practices, where applicable.



Always read the Operator's Manual before operating any equipment. Inspect equipment before using it, and be sure it is operating properly. Follow the product safety signs and use any safety features provided.

Form No. CCE201608SR160T4  
Replaces Form No. CCE201603SR160T4